

### Main

Range of product	Easy Modicon M200
Product or component type	Logic controller
[Us] rated supply voltage	24 V DC
Discrete I/O number	40
Discrete input number	I2...I5: 4 fast input I0, I1, I6, I7: 4 high speed input I8...I23: 16 regular input
Discrete output number	Q0...Q1: 2 fast output (PLS/PWM/PTO mode) Q2...Q15: 14 transistor output
Discrete input voltage	24 V
Discrete input voltage type	DC
Discrete input current	7 mA for input
Discrete input logic	Sink or source (positive/negative) type 1 conforming to EN/IEC 61131-2
Discrete output voltage	24 V DC
Discrete output current	0.5 A
Discrete output type	Transistor
Discrete output logic	Negative logic (sink)
Power consumption in W	10 W at 24 V DC (with max I/O)

### Complementary

Maximum number of I/O expansion module	4 with 64 discrete output(s) for relay output 4 with 144 discrete output(s) for transistor output
Supply voltage limits	20.4...28.8 V
Inrush current	35 A
Voltage state 1 guaranteed	$\geq 15$ V for input
Voltage state 0 guaranteed	$\leq 5$ V for input
Input impedance	3.3 kOhm for discrete input
Response time	1 ms turn-on, Q0...Q15 terminal(s) for output 1 ms turn-off, Q0...Q15 terminal(s) for output

Disclaimer: This documentation is not intended as a substitute for and is not to be used for determining suitability or reliability of these products for specific user applications

	<p>5 µs turn-off, I0, I1, I6, I7 terminal(s) for high speed input</p> <p>5 µs turn-on, I0, I1, I6, I7 terminal(s) for high speed input</p> <p>100 µs turn-off, I2...I5 terminal(s) for fast input</p> <p>35 µs turn-on, I2...I5 terminal(s) for fast input</p> <p>100 µs turn-off, I8...I13 terminal(s) for regular input</p> <p>35 µs turn-on, I8...I13 terminal(s) for regular input</p> <p>125 µs turn-off, I14...I23 terminal(s) for regular input</p> <p>55 µs turn-on, I14...I23 terminal(s) for regular input</p>
Configurable filtering time	<p>0 ms for input</p> <p>3 ms for input</p> <p>12 ms for input</p>
Maximum current per output common	<p>2 A at COM 0</p> <p>2 A at COM 1</p> <p>4 A at COM 2</p>
Output frequency	100 kHz for fast output (PWM/PLS mode) at Q0...Q1
Maximum leakage current	0.1 mA for transistor output
Maximum voltage drop	<1 V
Maximum tungsten load	<12 W for output and fast output
Protection type	Overload and short-circuit protection at 3.8 A
Reset time	1 s automatic reset
Memory capacity	512 byte internal flash for backup of programs
Data storage equipment	32 GB micro SD card (optional)
Battery type	BR2032 Li-CFx (Lithium-Carbon Monofluoride), battery life: 5 year(s)
Backup time	3 years at 25 °C (by interruption of power supply)
Execution time for 1 KInstruction	0.3 ms for event and periodic task
Execution time per instruction	0.2 µs Boolean
Exct time for event task	60 µs response time
Clock drift	<= 90 s/month at 25 °C
Regulation loop	Adjustable PID regulator up to 14 simultaneous loops
Positioning functions	PWM/PLS 2 channel(s) at 100 kHz
Control signal type	<p>Quadrature (x1, x2, x4) at 100 kHz for fast input (HSC mode)</p> <p>Pulse/direction at 100 kHz for fast input (HSC mode)</p> <p>Single phase at 100 kHz for fast input (HSC mode)</p> <p>CW/CCW at 100 kHz for fast input (HSC mode)</p>
Counting input number	4 fast input (HSC mode) at 100 kHz 32 bits
Integrated connection type	<p>USB port with mini B USB 2.0 connector</p> <p>Non isolated serial link serial 1 with terminal block connector and RS485 interface</p> <p>Non isolated serial link serial 2 with terminal block connector and RS232/RS485 interface</p> <p>Ethernet Modbus TCP/IP Ethernet with RJ45 connector and 1 Ethernet port 10/100BASE-T interface</p> <p>Isolated serial link serial 2 with terminal block connector and RS485 interface</p>
Transmission rate	<p>1.2...115.2 kbit/s (115.2 kbit/s by default) for bus length of 15 m for RS485</p> <p>1.2...115.2 kbit/s (115.2 kbit/s by default) for bus length of 3 m for RS232</p> <p>12 Mbit/s for USB</p> <p>10/100 Mbit/s for bus length of 100 m for Ethernet Modbus TCP/IP</p>
Communication port protocol	<p>USB port: USB - SoMachine-Network</p> <p>Non isolated serial link: Modbus master/slave - RTU/ASCII or SoMachine-Network</p> <p>Ethernet Modbus TCP/IP: Modbus TCP/IP client/server</p>
Local signalling	<p>1 LED (green)PWR:</p> <p>1 LED (green)RUN:</p> <p>1 LED (red)module error (ERR):</p> <p>1 LED (green)SD card access (SD):</p> <p>1 LED (red)BAT:</p> <p>1 LED (green)SL1:</p> <p>1 LED per channel (green)I/O state:</p> <p>2 LEDs (green)communication (LK/ACT 10/100):</p>
Electrical connection	<p>Mini B USB 2.0 connectorfor a programming terminal</p> <p>RJ45 connectorfor connecting Ethernet network</p> <p>removable screw terminal blockfor inputs</p> <p>removable screw terminal blockfor outputs</p> <p>removable screw terminal block, 3 terminal(s) for connecting the 24 V DC power supply</p> <p>removable screw terminal block, 4 terminal(s) for connecting the serial link1</p>
Maximum cable distance between devices	<p>Unshielded cable: &lt;50 m for input</p> <p>Shielded cable: &lt;10 m for fast input</p> <p>Shielded cable: &lt;10 m for high speed input</p>

	Unshielded cable: <150 m for output
Insulation	Non-insulated between inputs Between output and internal logic at 1780 V AC Between output groups at 1780 V AC Between supply and internal logic at 1780 V AC Between input and internal logic at 500 V AC Between fast input and internal logic at 500 V AC Between input groups at 500 V AC
Marking	CE
Mounting support	Top hat type TH35-15 rail conforming to IEC 60715 Top hat type TH35-7.5 plate or panel with fixing kit conforming to IEC 60715
Height	90 mm
Depth	70 mm
Width	175 mm
Net weight	0.483 kg

## Environment

IP degree of protection	IP20 with protective cover in place
Product certifications	RCM IACS E10 CSA CULus
Standards	EN/IEC 61131-2 EN/IEC 61010-2-201
Electromagnetic compatibility	Electrostatic discharge immunity test - test level: 8 kV (air discharge) conforming to EN/IEC 61000-4-2 Electrostatic discharge immunity test - test level: 6 kV (contact discharge) conforming to EN/IEC 61000-4-2 Susceptibility to electromagnetic fields - test level: 10 V/m (80 MHz...3 GHz) conforming to EN/IEC 61000-4-3 Magnetic field at power frequency - test level: 30 A/m conforming to EN/IEC 61000-4-8 Electrical fast transient/burst immunity test - test level: 2 kV (power lines) conforming to EN/IEC 61000-4-4 Electrical fast transient/burst immunity test - test level: 2 kV (relay output) conforming to EN/IEC 61000-4-4 Electrical fast transient/burst immunity test - test level: 1 kV (I/O) conforming to EN/IEC 61000-4-4 Electrical fast transient/burst immunity test - test level: 1 kV (serial link) conforming to EN/IEC 61000-4-4 1.2/50 $\mu$ s shock waves immunity test - test level: 1 kV (power lines (DC)) conforming to EN/IEC 61000-4-5 1.2/50 $\mu$ s shock waves immunity test - test level: 2 kV (power lines (AC)) conforming to EN/IEC 61000-4-5 1.2/50 $\mu$ s shock waves immunity test - test level: 2 kV (relay output) conforming to EN/IEC 61000-4-5 1.2/50 $\mu$ s shock waves immunity test - test level: 1 kV (I/O) conforming to EN/IEC 61000-4-5 1.2/50 $\mu$ s shock waves immunity test - test level: 1 kV (shielded cable) conforming to EN/IEC 61000-4-5 1.2/50 $\mu$ s shock waves immunity test - test level: 0.5 kV (power lines (DC)) conforming to EN/IEC 61000-4-5 1.2/50 $\mu$ s shock waves immunity test - test level: 1 kV (power lines (AC)) conforming to EN/IEC 61000-4-5 Conducted RF disturbances - test level: 10 V (0.15...80 MHz) conforming to EN/IEC 61000-4-6 Conducted emission - test level: 79 dB $\mu$ V/m QP/66 dB $\mu$ V/m AV (power lines (AC)) conforming to EN/IEC 55011 Conducted emission - test level: 73 dB $\mu$ V/m QP/60 dB $\mu$ V/m AV (power lines (AC)) conforming to EN/IEC 55011 Radiated emission - test level: 40 dB $\mu$ V/m QP class A (10 m) conforming to EN/IEC 55011 Radiated emission - test level: 47 dB $\mu$ V/m QP class A (10 m) conforming to EN/IEC 55011 Electrical fast transient/burst immunity test - test level: 1 kV (Ethernet line) conforming to EN/IEC 61000-4-4
Shock resistance	15 gn for 11 ms 30 gn for 6 ms
Immunity to microbreaks	2 ms
Vibration resistance	3.5 mm at 5...8.4 Hz on symmetrical rail 1 gn at 8.4...150 Hz on symmetrical rail 3.5 mm at 5...8.7 Hz on panel mounting 2 gn at 8.7...150 Hz on panel mounting
Relative humidity	10...95 %, without condensation (in operation) 10...95 %, without condensation (in storage)

Ambient air temperature for operation	0...55 °C (horizontal installation)
Ambient air temperature for storage	-25...70 °C
Pollution degree	<= 2
Operating altitude	0...2000 m
Storage altitude	0...3000 m

## Packing Units

Package 1 Weight	7.100 kg
Package 1 Height	9.000 cm
Package 1 width	18.400 cm
Package 1 Length	13.800 cm

## Offer Sustainability

Sustainable offer status	Green Premium product
EU RoHS Directive	Pro-active compliance (Product out of EU RoHS legal scope) <a href="#">EU RoHS Declaration</a>
Mercury free	Yes
RoHS exemption information	<a href="#">Yes</a>
China RoHS Regulation	<a href="#">China RoHS declaration</a>
Environmental Disclosure	<a href="#">Product Environmental Profile</a>
Circularity Profile	<a href="#">End of Life Information</a>
WEEE	The product must be disposed on European Union markets following specific waste collection and never end up in rubbish bins

---

Dimensions Drawings

---

Dimensions

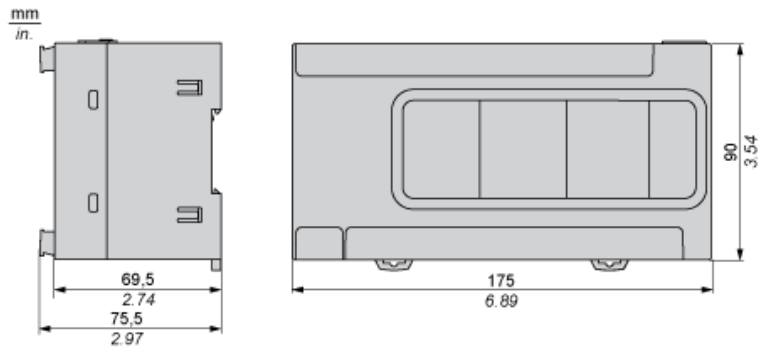

---

Mounting and Clearance

---

Mounting on a Rail

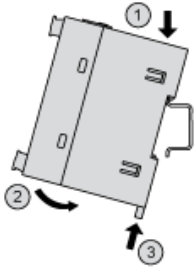

Direct Mounting on a Panel Surface

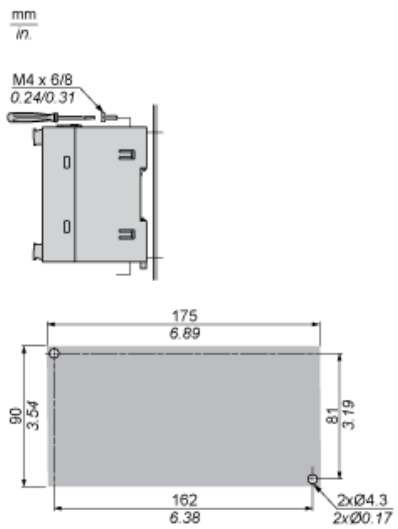

Mounting Position

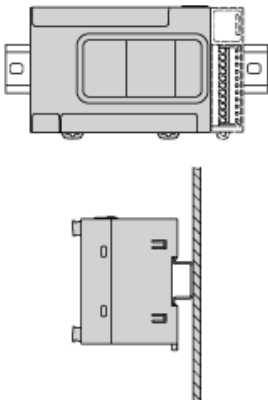

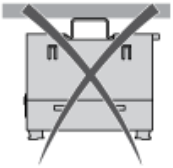
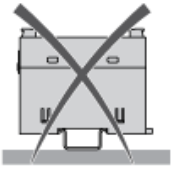

## Clearance

mm  
in.

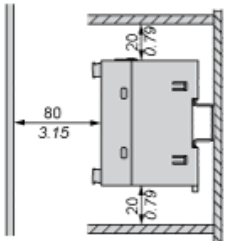
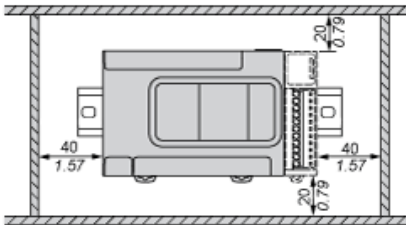

## TMCR2...Installation

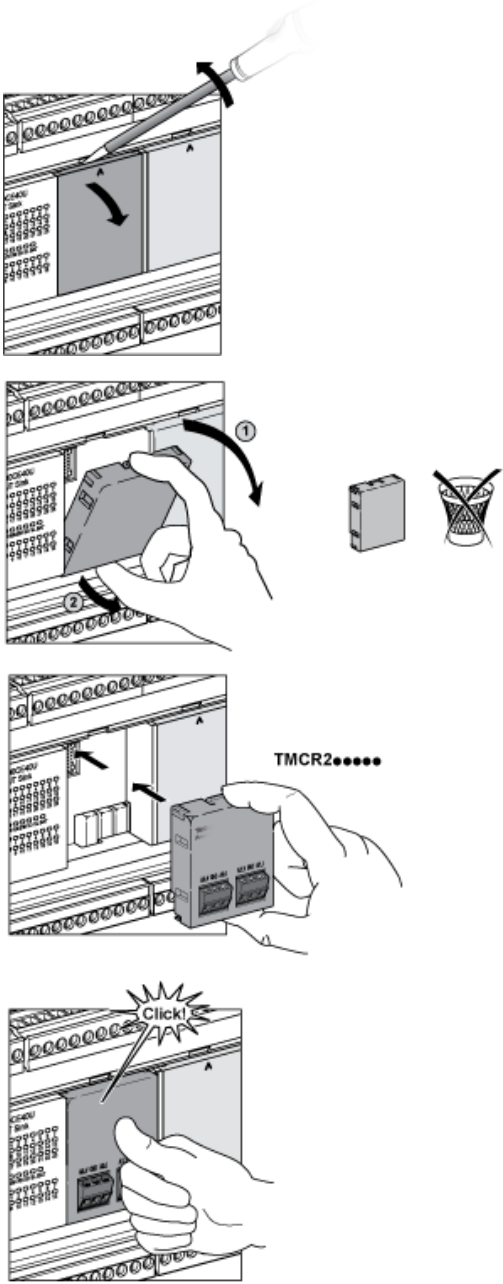

## TMCR2... De-Installation

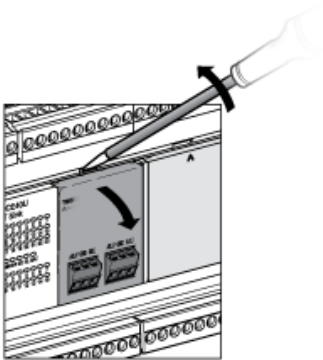



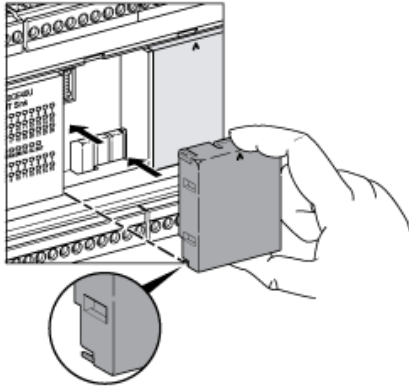
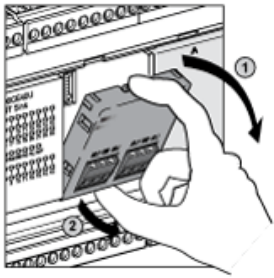

Wiring Diagram / Connections Schema

DC Power Supply

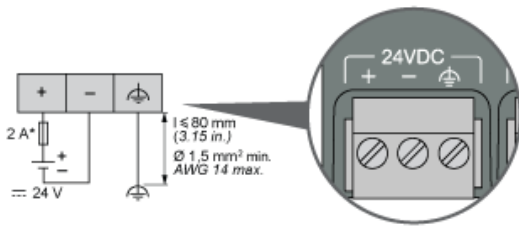
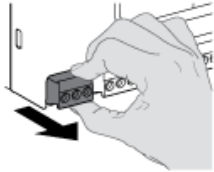

(\*) Type T fuse

Digital Inputs (Sink or Source)

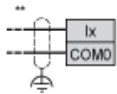
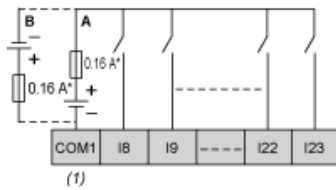
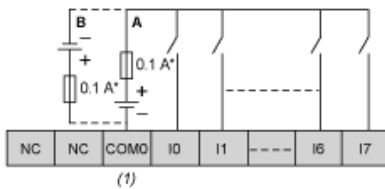

- (\*) Type T fuse
- A : Sink wiring (positive logic)
- B : Source wiring (negative logic)
- (\*\*) Fast inputs

## Regular and Fast Transistor Output

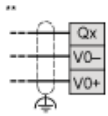
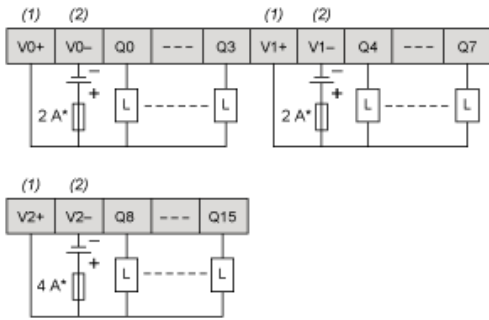

- (\*) Type T fuse
- (\*\*) Fast outputs
- (1) The V0+, V1+ and V2+ terminals are not connected internally.
- (2) The V0-, V1- and V2- terminals are not connected internally.

## Ethernet Connection

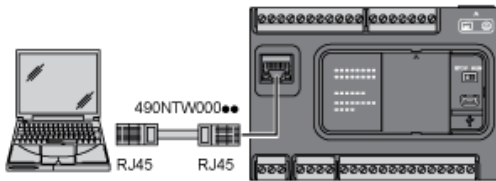

Pin N°	Signal
1	TD +
2	TD —
3	RD+
4	—
5	—
6	RD —
7	—
8	—

## USB Mini-B Connection

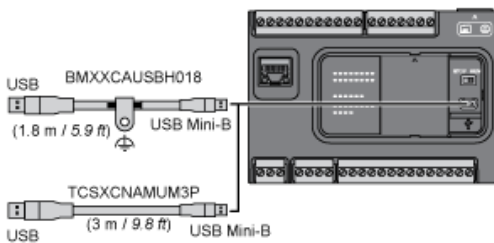

### SL1 Connection

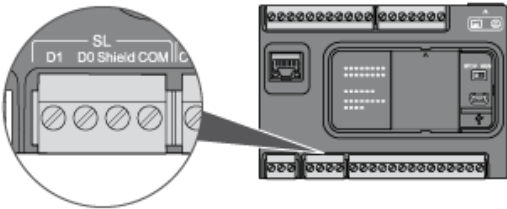

- D1 : D1 (A+)
- D0 : D0 (B-)
- Shield : Shield
- COM : 0 V Com